

Zmac/1000®



The Zmac/1000® Electric and Zmac/1000® Air offer full performance in a portable, compact hoist.

The two hoists are UL and CUL listed and meet or exceed all current ANSI and OSHA requirements. These hoists are compact, quiet and durable. Using a sophisticated, patented traction principle, the electric and air models give safe and reliable performance. Easy to handle, the Zmac/1000® (E) and Zmac/1000®(A) have been designed to meet your most demanding requirements.

Key Features of Zmac/1000® Electric and Zmac/1000® Air:

- Control descent
- Self-reeving
- Patent Traction Technology
- Carrying handles
- Pendant control (optional)
- Secondary Bisolock (optional with the Zmac/1000® Air)
- The Zmac/1000® Electric features quiet run technology for smooth and silent operation.
- **Available in rental fleet only**

Protect your Investment!
Use hoist cover 700784-1
or 701018-1 on page 171.

Specifications:	Spider Zmac / 1000® Electric (700783-1)	Spider Zmac / 1000® Air (701127-1)
Gross Load Capacity:	1,000 lb (453.6 kg)	1,000 lb (453.6 kg)
Dimensions:	15.7 x 9.5 x 13 in. (399 x 241 x 330 mm)	15.1 x 10 x 14.75 in. (385 x 254 x 375 mm)
Weight:	72 lb (32.7 kg)	68 lb (30.8 kg)
Travel Speed:	35 ft/min (10.7 m/min)	35 ft/min (10.7 m/min)
Power:	208V (+/-10%)	Air consumption: 100 psi, 75 cfm
Wire Rope Diameter:	5/16 in. (8 mm)	5/16 in. (8 mm)
Other:	<ul style="list-style-type: none"> • Aluminum and stainless steel • "3-piece" construction • Reliable direct drive power transfer • Low voltage indicator 	<ul style="list-style-type: none"> • Driven by a 4HP Air motor

Zmac/1000® is a registered mark of Nihon Bisoh Co, Japan. Reference is made to this product in Spider's rental fleet and installed contractor fleets.

**For welding installation details,
see page 39.**

Zmac/1000[®] Electric

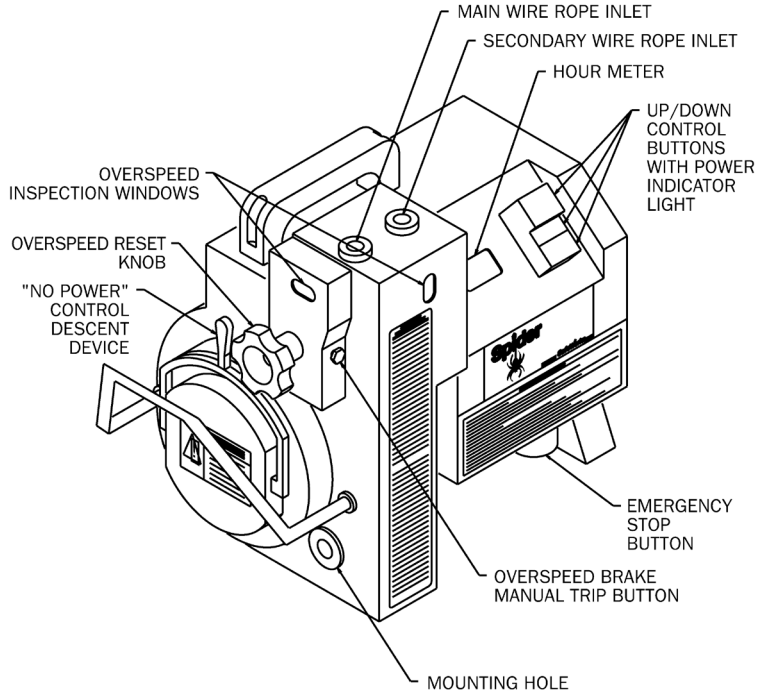

• Available in rental fleet only

Zmac/1000[®] Air

